

MACC300 series

AIR UNITS (F.R.L.UNIT)

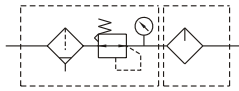

Symbol:



Specification:

Model	MACC300	
Bore No.	8A	10A
Port size	PT 1/4	PT 3/8
Medium	Air	
Operating pressure range	0~9.9 kgf/cm ² (0~0.99 MPa)	
Proof pressure	15 kgf/cm ² (1.5 MPa)	
Regulation pressure range	0.5~8.5 kgf/cm ² (0.05~0.850 MPa)	
Effective orifice	28mm ²	30mm ²
Ambient temperature	-5~+60°C (No freezing)	
Filtration	Standard: 5 μm Option: 40 μm	
Lubricating oil capacity	50c.c	
Min. Flow for oil drip	50 ℓ/min	60 ℓ/min
Recommended lubricating oil	Turbine oil ISO-VG32	
Attachment	Pressure gauge, L-type bracket	
Weight	660 g	

Order example:

MACC300 — 8A — BSP

MODEL

BORE SIZE

8A: PT 1/4
10A: PT 3/8

PORT THREAD

Blank: PT thread
BSP: BSP thread
NPT: NPT thread

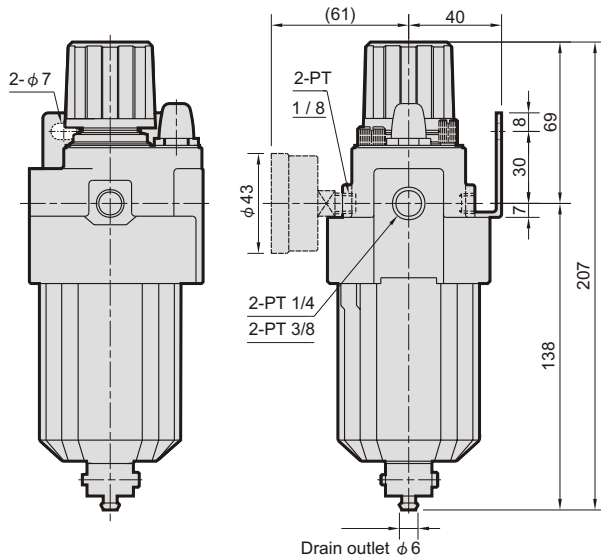
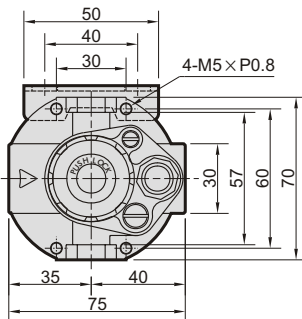

Flow feature:

