

MCHB series

PARALLEL GRIPPERS

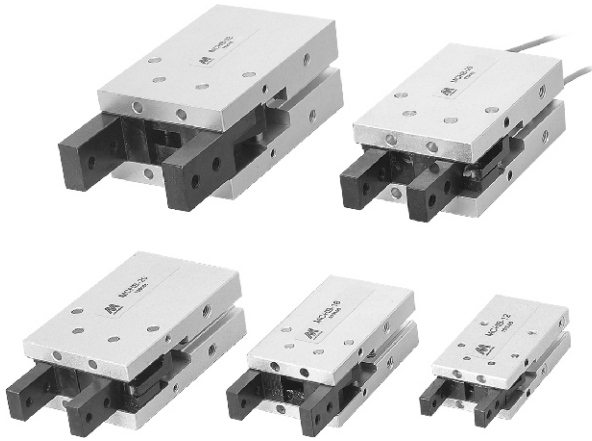

Order example:

MCHB – 16

MODEL

TUBE I.D.

Features:

- Available with a comprehensive selection of bore size (ϕ 12~32) for the various needs.
- The highly accurate, air-driven open closed work.

Specification:

Model		MCHB				
Acting Type		Double Acting				
Tube I.D. (mm)		12	16	20	25	32
Port size Rc(PT)		M3×0.5		M5×0.8		
Medium		Air				
Operating pressure range		1.5~7 kgf/cm ²				
Ambient temperature		-5~+60°C (No freezing)				
Max frequency		180 Cycles/min				
Lubrication	Cylinder	Not required				
	Lever	Grease				
Max arm length (L) (mm)		30	40	60	70	85
Theoretical holding force kgf-cm	Closed side	0.8	2.4	4.7	7.5	10
	Opened side	0.5	1.8	3.5	6.0	8.5
Lever open / Close stroke		6	8	12	14	16
Sensor switch		RCE, RCE1				
Weight (g)		66	144	255	419	719

※ Gripping point length L=30mm, Pressure=5kgf/cm².

Length of gripping point

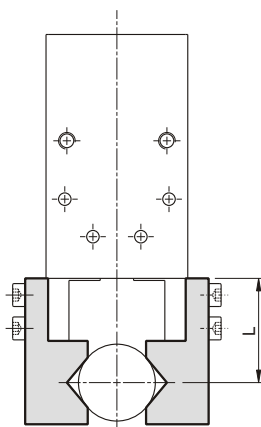

Installation of sensor switch

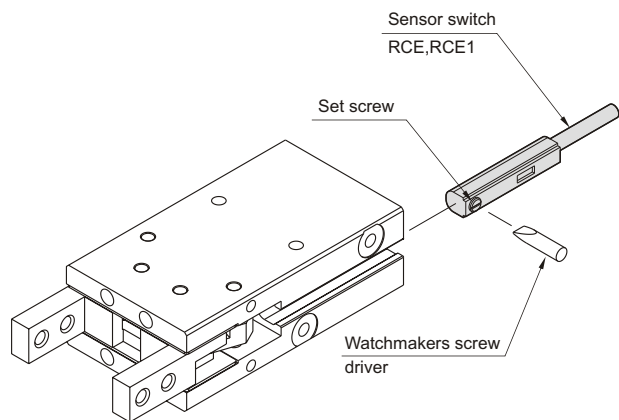

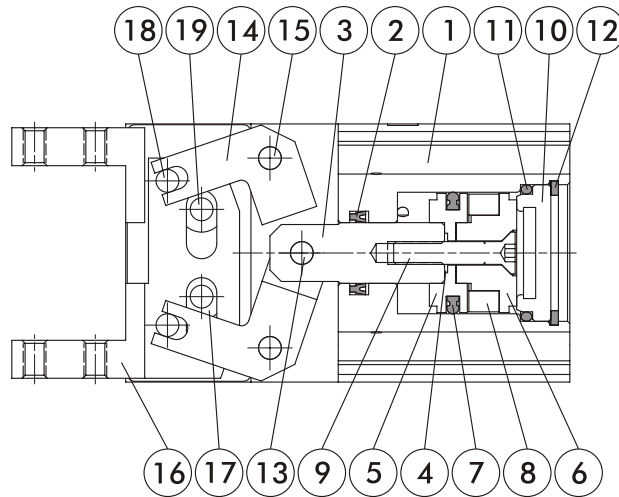

Material

No.	Part name	Material
1	Body	Aluminum alloy
2	Rod packing	NBR
3	Piston rod	Stainless steel
4	Gasket	NBR
5	Piston-R	Aluminum alloy
6	Piston-H	Aluminum alloy
7	Piston packing	NBR
8	Magnet ring	Magnet material
9	Screw	Stainless steel
10	Head cover	Rolled steel
11	Cover ring	NBR
12	Stop ring	Spring steel
13	Spindle river	Bearing steel
14	Grip per	Carbon steel
15	Grip rivet	Carbon steel
16	Grip per	Carbon steel
17	Bush	Stainless steel
18	Grip rivet	Bearing steel
19	Grip rivet	Carbon steel
20	Screw	SCM
21	Screw	SCM
22	Washer for grip	Stainless steel

MCHB Dimensions $\phi 12 \sim \phi 32$

PARALLEL GRIPPERS

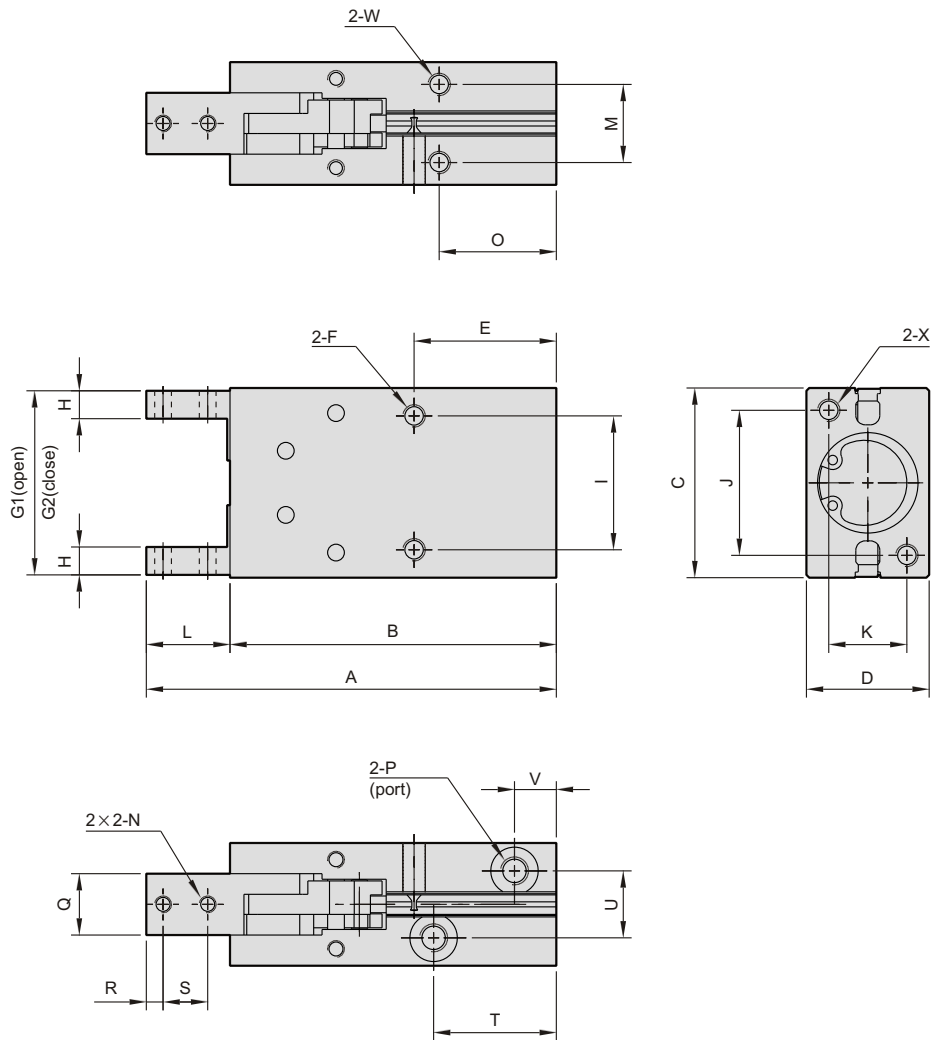

Code Tube I.D.	A	B	C	D	E	F	G1	G2	H	I	J	K	L	M	N	O	P	Q	R	S
12	63.5	50.5	28	16	20	M3×0.5×5 depth	27	21	4	18	17	10	13	10	M3×0.5	16	M3×0.5×5 depth	7	3	6
16	73.5	58.5	34	22	25.5	M4×0.7×11 depth	33	25	5	24	26	14	15	14	M3×0.5	21	M5×0.8×5 depth	11	3	8
20	88.5	69.5	45	26	25	M5×0.8×8 depth	44	32	6	30	35	16	19	16	M4×0.7	19	M5×0.8×5 depth	12	4	10
25	102.5	78.5	52	32	28	M6×1.0×10 depth	51	37	8	36	40	20	24	20	M5×0.8	22	M5×0.8×5 depth	14	5	12
32	120.5	90.5	60	40	34	M6×1.0×10 depth	59	43	10	44	46	24	30	26	M6×1.0	26	M5×0.8×5 depth	20	7	15

Code Tube I.D.	T	U	V	W	X
12	23	10.2	7.5	M3×0.5×5 depth	M3×0.5×5 depth
16	22	12	7.5	M4×0.7×7 depth	M4×0.7×7 depth
20	26	13	8	M5×0.8×8 depth	M5×0.8×8 depth
25	29	18	8.5	M6×1.0×10 depth	M6×1.0×10 depth
32	35	24	10.5	M6×1.0×10 depth	M6×1.0×10 depth