

Features

- Positioning of Square work pieces.
- The housing: high-tensile aluminum and special hard-coated.
- The 4-jaw grippers is designed in lower height with long stroke.

Specification

Model	MCHGF				
Acting type	Double acting				
Body diameter(mm)	50	64	80	100	125
Stroke (mm)	8	12	16	20	26
Medium	Air				
Operating pressure range	0.2~0.8 MPa				
Repeatability	0.05 mm				
Ambient temperature	-10℃~+60℃ (No freezing)				
Lubrication	Not required				
Sensor switch (※1)	RH: Reed switch, RHN: NPN, RHP: PNP				
Weight (kg)	0.24	0.42	0.85	1.51	2.45

Order example

MCHGF – 64 M

MODEL

BODY DIAMETER
50, 64, 80,
100, 125

M: Magnet

Dimensions

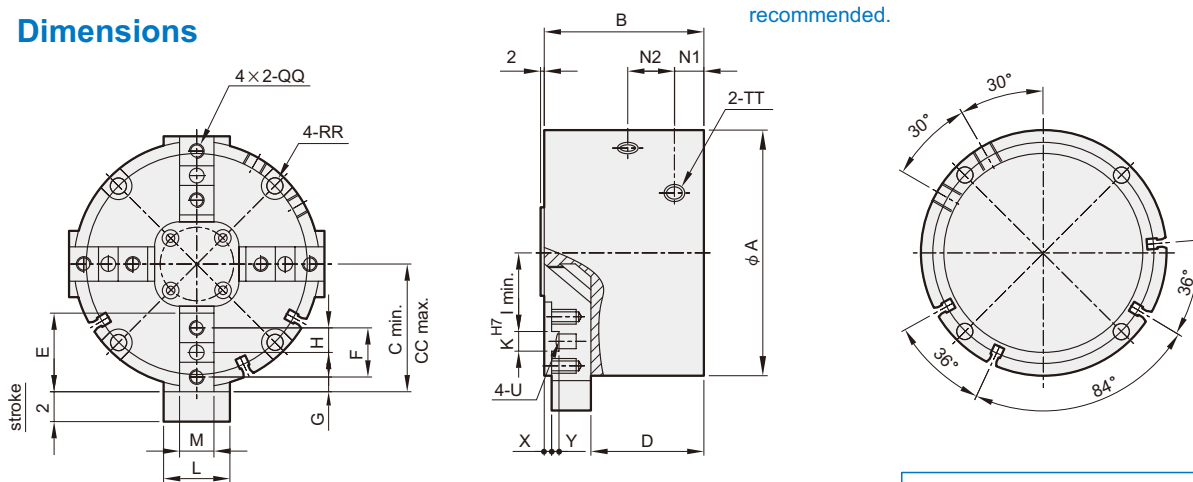

Code Model	A	B	C	CC	D	E	F	G	H	I	K	L	M	N1	N2
MCHGF-50	50	39	26.5	30.5	28	18	12	3	6	15	5	14	8.2	8.1	14.8
MCHGF-64	64	47.5	32	38	32	20	13	4	6.5	19	5	17	10.2	10	16.5
MCHGF-80	80	56.5	42	50	39.5	25	16	5	8	26	6	23	12.2	10	22
MCHGF-100	100	65	52	62	46	32	20	6	10	32	8	27	14.2	12	24
MCHGF-125	125	76	65.5	78.5	53.5	40	24	8.5	12	41	8	30	16.2	13.5	28.5

Code Model	QQ	RR	TT	U	X	Y
MCHGF-50	M3×0.5×7dp	φ 3.4 thru, 7C/B×5dp P.C.D44	M5	φ 4	—	2
MCHGF-64	M4×0.7×8dp	φ 5.5 thru, 10C/B×6dp P.C.D56	M5	φ 4	2	2.5
MCHGF-80	M5×0.8×9dp	φ 6.4 thru, 11C/B×7dp P.C.D70	M5	φ 5	3	3
MCHGF-100	M6×1.0×12dp	φ 6.6 thru, 11C/B×7dp P.C.D90	Rc1/8	φ 6	3	3
MCHGF-125	M8×1.0×12dp	φ 8.5 thru, 15C/B×9dp P.C.D112	Rc1/8	φ 6	3	3.5

MCHGF-50 auto switch mounting groove position

