

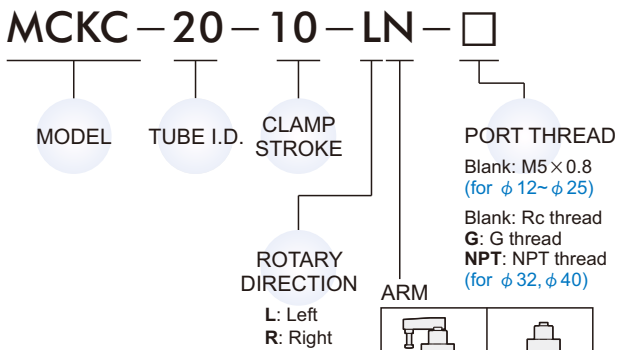

### Order example

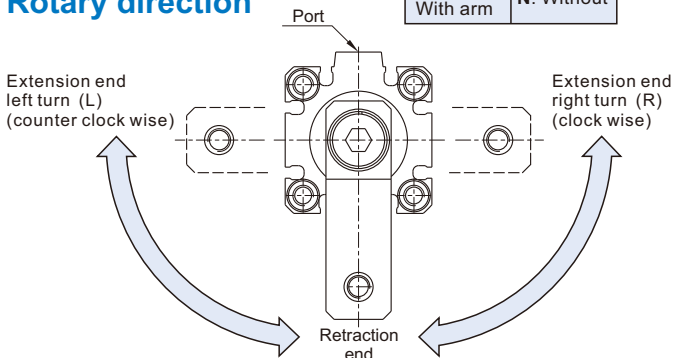

### Rotary direction



### Clamping arm mounting methods

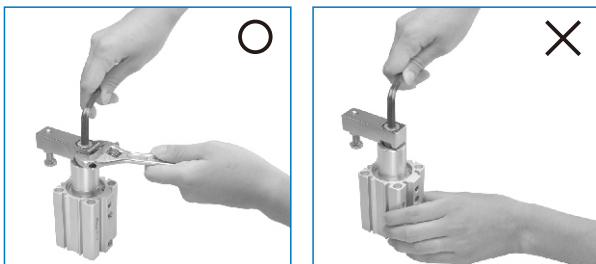

### Features

- Ultra compact, light weight and space saving cylinder.
- Ideal for use in machinery where space is limited and incorporating sensor groove which enables flush fitting of sensors.
- The sensor can freely mounted the four sides.
- Magnetic as standard.

### Specification

Model	MCKC					
Acting type	Double acting					
Tube I.D. (mm)	12	16	20	25	32	40
Port size	M5 × 0.8				Rc1/8	
Rotary angle	90° ± 10°					
Rotary direction	Left (L) · Right (R)					
Rotary stroke (mm)	7.5		9.5		15	
Clamp stroke (mm)	10, 20		10, 20, 30			
Medium	Air					
Operating pressure range	0.1~0.9 MPa					
Ambient temperature	-5°C~+60°C (No freezing)					
Available speed range	50~200 mm/sec					
Non-rotating accuracy (※1)	±2°	±1.3°	±1.2°	±1°		
Lubrication	Not required					
Sensor switch (※2)	—		RCE, RCE1			
	RNE: NPN, RPE: PNP					

※1. Arm during clamping (Clamp part).

※2. RCE, RCE1 specifications please refer to page 5-6.

### Moment of inertia

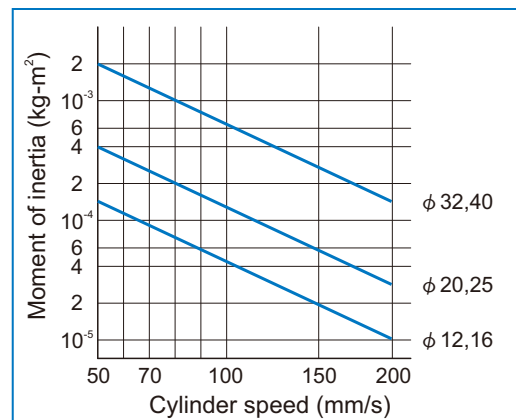

### Installation of sensor switch

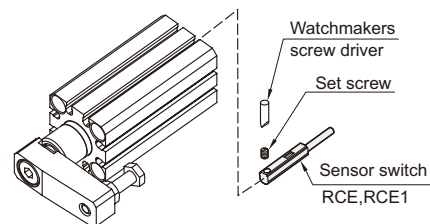

$\phi 12, \phi 16, \phi 40$

$\phi 20, \phi 25, \phi 32$

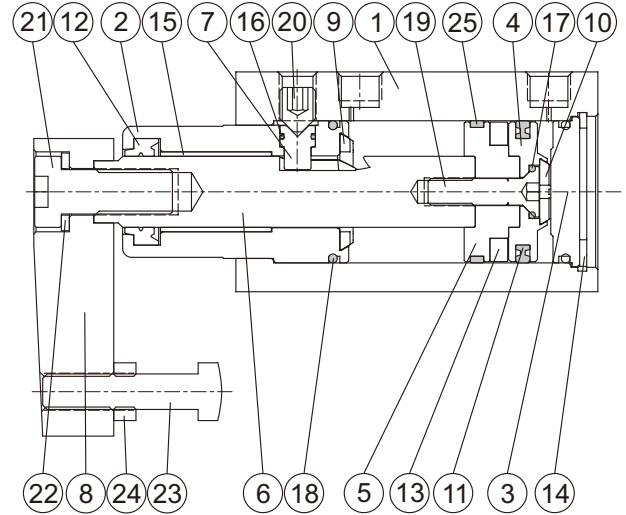
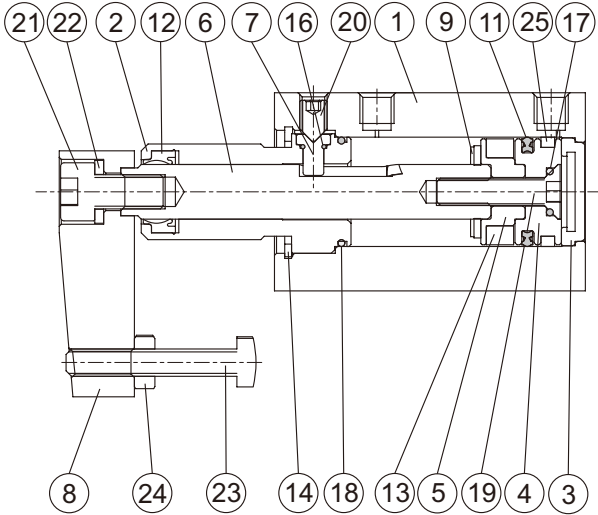

### Material

No.	Part name	Material	Note
1	Body	Aluminum alloy	
2	Rod cover	Aluminum alloy	
3	End cover	Aluminum alloy	
4	Piston	Aluminum alloy	
5	Piston for magnet ring	Aluminum alloy	
6	Piston rod	SCM	
7	Guide pin	SCM	
8	Arm	Carbon steel	
9	Rod cushion	NBR	
10	End cushion	NBR	※1
11	Piston packing	NBR	
12	Rod packing	NBR	
13	Magnet ring	Magnet material	

No.	Part name	Material	Note
14	Snap ring	Stainless steel	※2
15	Bush	Copper	※3
16	O-ring	NBR	
17	O-ring	NBR	
18	O-ring	NBR	
19	Bolt	Stainless steel	
20	Set screw	SCM	
21	Bolt	SCM	
22	Spring washer	Spring steel	
23	Bolt	SCM	
24	Nut	Carbon steel	
25	Wear ring	Teflon	

※1. For  $\phi 20 \sim \phi 40$

※2. Carbon steel (for  $\phi 12, \phi 16$ )

※3. For  $\phi 32, \phi 40$

### Theoretical force



Unit: N

Tube I.D. (mm)	Piston rod (mm)	Operating direction	Piston area (mm <sup>2</sup> )	Operating pressure (MPa)								
				0.1	0.2	0.3	0.4	0.5	0.6	0.7	0.8	0.9
12	6	A	113	11.3	22.6	33.9	45.2	56.5	67.8	79.1	90.4	101.7
		B	85	8.5	17.0	25.5	34.0	42.5	51.0	59.5	68.0	76.5
16	8	A	201	20.1	40.2	60.3	80.4	100.5	120.6	140.7	160.8	181.0
		B	151	15.1	30.2	45.2	60.3	75.4	90.5	105.6	120.6	135.7
20	12	A	314	31.4	62.8	94.2	125.7	157.1	188.5	219.9	251.3	282.7
		B	201	20.1	40.2	60.3	80.4	100.5	120.6	140.7	160.8	181.0
25	12	A	491	49.1	98.2	147.3	196.4	245.4	294.5	343.6	392.7	441.8
		B	378	37.8	75.6	113.3	151.1	188.9	226.7	264.4	302.2	340.0
32	16	A	804	80.4	160.8	241.3	321.7	402.1	482.5	563.0	643.4	723.8
		B	603	60.3	120.6	181.0	241.3	301.6	361.9	422.2	482.5	542.9
40	16	A	1257	125.7	251.4	377.1	502.8	628.5	754.2	879.9	1005.6	1131.3
		B	1056	105.6	211.2	316.8	422.4	528.0	633.6	739.2	844.8	950.4

### Cylinder weight

Unit: g

Model	Basic weight MCKC	Basic weight MCKC-N	Stroke 10 mm MCKC
Tube I.D.			
$\phi 12$	66	52	16
$\phi 16$	100	66	23
$\phi 20$	266	176	38
$\phi 25$	319	229	46
$\phi 32$	573	382	69
$\phi 40$	652	461	74

$\phi 12, \phi 16$

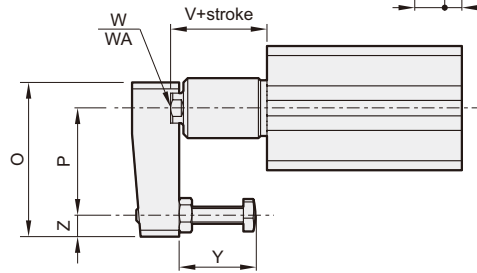
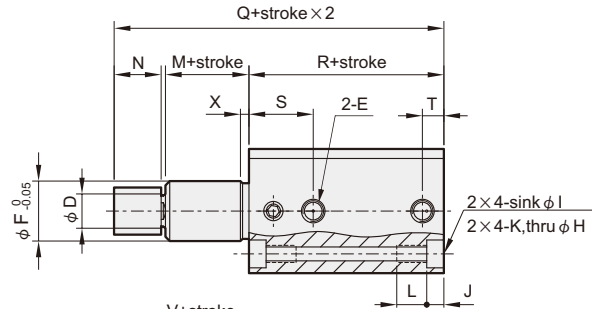
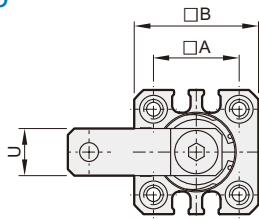

$\phi 20, \phi 25$

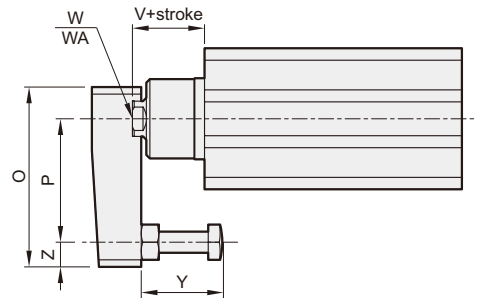
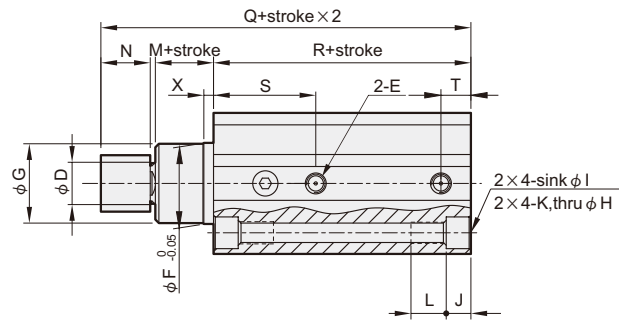
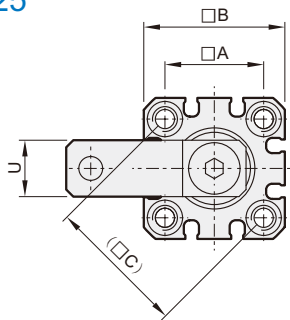

$\phi 32, \phi 40$

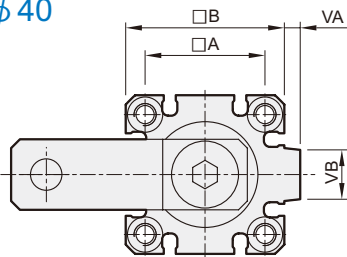

Code Tube I.D.	A	B	C	D	E	F	G	H	I	J	K	L	M	N	O	P	Q	R	S	T	U
12	15.5	25	-	6	M5×0.8	11	-	3.5	6.5	4	M4×0.7	7	9.5	8	29	20	54	35.5	15	5	8
16	20	29	-	8	M5×0.8	14	-	3.5	6.5	4	M4×0.7	7	9.5	11	36	25	57	35.5	15	5	11
20	25.5	36	36	12	M5×0.8	18	17.9	5.4	9	7	M6×1.0	10	6.5	14	51	35	84	62	28	8.7	16
25	28	40	39.6	12	M5×0.8	23	22.5	5.4	9	7	M6×1.0	10	6.5	14	51	35	85	63	29	8.5	16
32	34	45	-	16	Rc1/8	30	29.5	5.5	9	7	M6×1.0	10	15.5	18	67	45	107	71.5	28	11	20
40	40	52	-	16	Rc1/8	30	29.5	5.5	9	7	M6×1.0	10	23	18	67	45	108	65	27	8	20

Code Tube I.D.	V	VA	VB	W (ROD thread)	WA	X	Y	Z
12	12.5	-	-	M3×0.5×5.5L	Across flats 5×2.5L	2	7~18	4
16	12.5	-	-	M5×0.8×6.5L	Across flats 7×2.5L	2	7~20	5
20	10.5	-	-	M8×1.25×14L	Across flats 10×3L	3	12~25	7
25	10.5	-	-	M8×1.25×14L	Across flats 10×3L	3	12~25	7
32	22	4.5	14	M10×1.5×19L	Across flats 14×5.5L	3	12~25	10
40	29.5	5	14	M10×1.5×19L	Across flats 14×5.5L	3	12~25	10