



### Features

- Reducing the length from installation side to surface of slide to save space.
- Using servo stepper motor to enhance accuracy by driving timing belt with minimum pitch.
- Using four linear ball bearings to sustain the load of slide and maintain stable and smooth motion.
- Integrate the controller into stepper motor and it has memory function for programming.
- Three-phase stepper motor: incremental type 10000P/R, including 3 input - 2out.
- All in one: program control mode, pulse control mode and terminal control mode.

### Specification

Model	MEAT
Tube I.D. (mm)	25
Bearing	Linear ball bearings
Velocity	48~1000 mm/s
Horizontal load	5 kg
Repeatability	± 0.1 mm
Ambient temperature	+5°C ~ +40°C

### Table for standard stroke

Tube I.D.	Stroke (mm)	Max. stroke
25	100,200,300,400,500,600,700	750

※ Minimum stroke unit 1mm.

※ Please consult us if stroke out of specification.

### Order example

MEAT-25-200-1

MODEL

TUBE I.D.

STROKE

Blank: Standard  
1: With I/O card  
(Should be ordered alone  
EAT-1: Expansion I/O card)

Loading direction

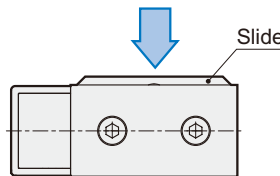

### Velocity-Horizontal load

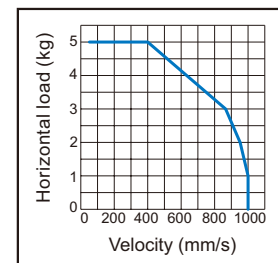

### Dimensions

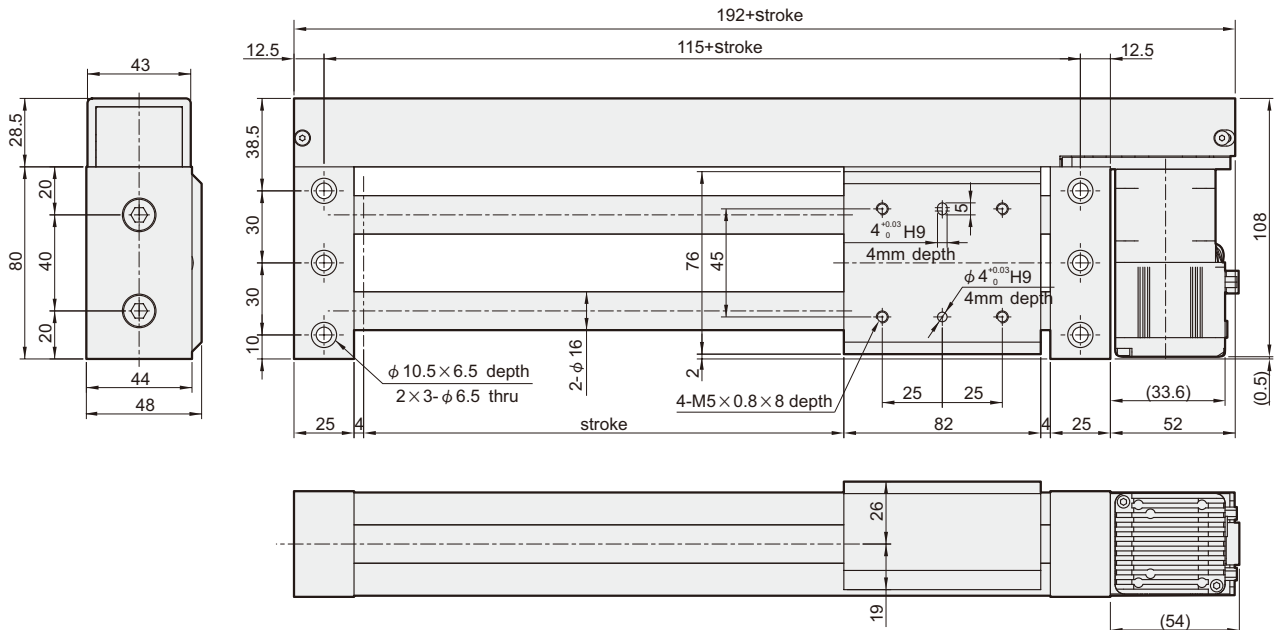

## SLIDER ELECTRIC CYLINDER - BELT DRIVEN

### Specification

Motor Size	Servo type three-phase stepper motor	
Power	DC 24V	
Rated current / Max. instant current	4A / 6A	
Rated torque	0.25 N.m	
Cooling type	Natural cooling	
Resolution encoder	Incremental type 10000 resolution/per cycle	
Control mode	Position · terminal control · Modbus communication control	
Position control	Max input pulse frequency	Differential Signaling: Below 500K PPS; Open Collector Signaling: 200K PPS
	Pulsed mode	CW/CCW · Pulse/DIR
	Smoothing filter	Cushion, Trapezoidal velocity profile acceleration /deceleration
	Electronic gear ratio	Electronic gear ratio (A/B) > 1/9999, A/B < 9999
	Registration complete check	0 ~ 999 Pulse
Terminal control	Internal operation instruction	Executing movement command from Windows Terminal
	Scripts edit control	Program input point, programmable set external INPUT ON/OFF signal for positioning.
Interface	RS232(for Windows Terminal) / RS485 / Modbus	
JOG function	Run manually(The speed is according to the parameter of configuration)	
Brake function	Output the control signal of Z-Axis brake, according to the servo ON/OFF status.	
Abnormal function	Servo control stop, positive / negative turn actuation restricted	
Protective device	Over current, over voltage, over temperature, encoder abnormal, low voltage, input pulse over limit, follow abnormal detection.	
Input signal	Servo control ON/OFF, zero point signal, pulse control signal.	
Output Signal	Servo control ready (Z axis brake control signal ), location complete, actuation abnormal output (parameter setting).	

※ Recommend installation environment: Places without moisture, oily dusty, corrosive and flammable liquid. Without floating dusty and metallic particle. Firm and static places without electrical interference, megathermal equipment.

### Dimensions

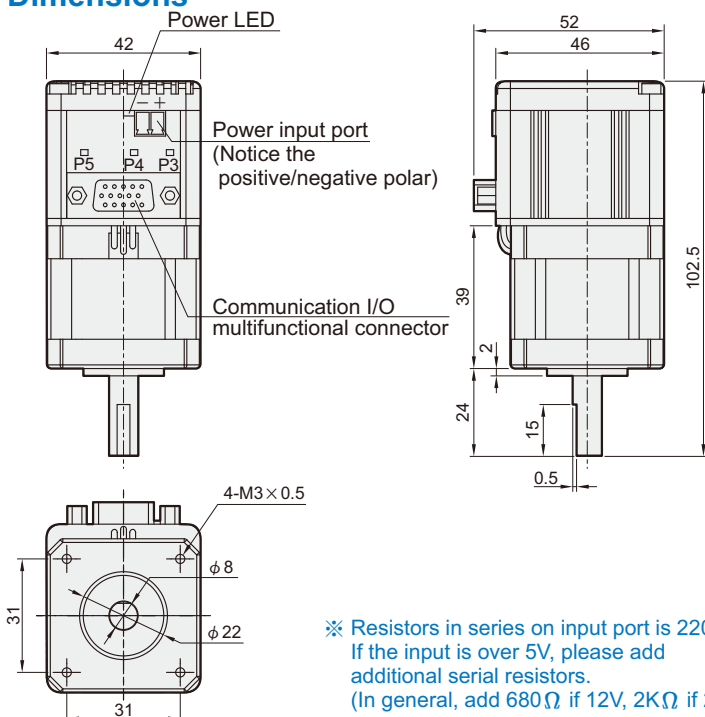

※ Resistors in series on input port is 220Ω. If the input is over 5V, please add additional serial resistors. (In general, add 680Ω if 12V, 2KΩ if 24V)

### Definition of three-row 15pin DE-15 connector

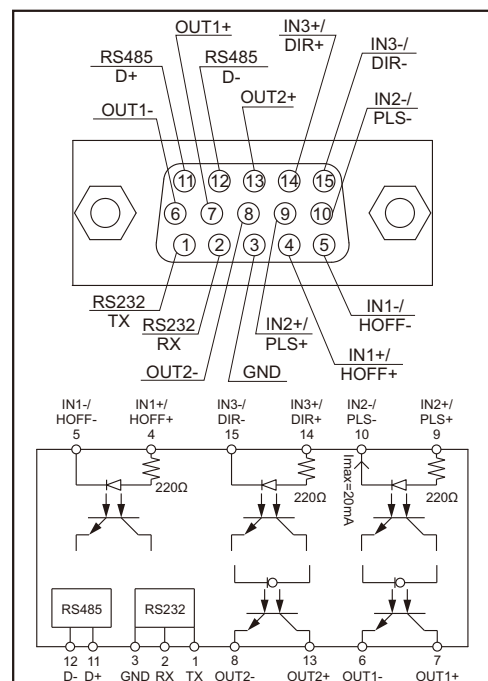

### Dimensions(Including expansion I/O card)

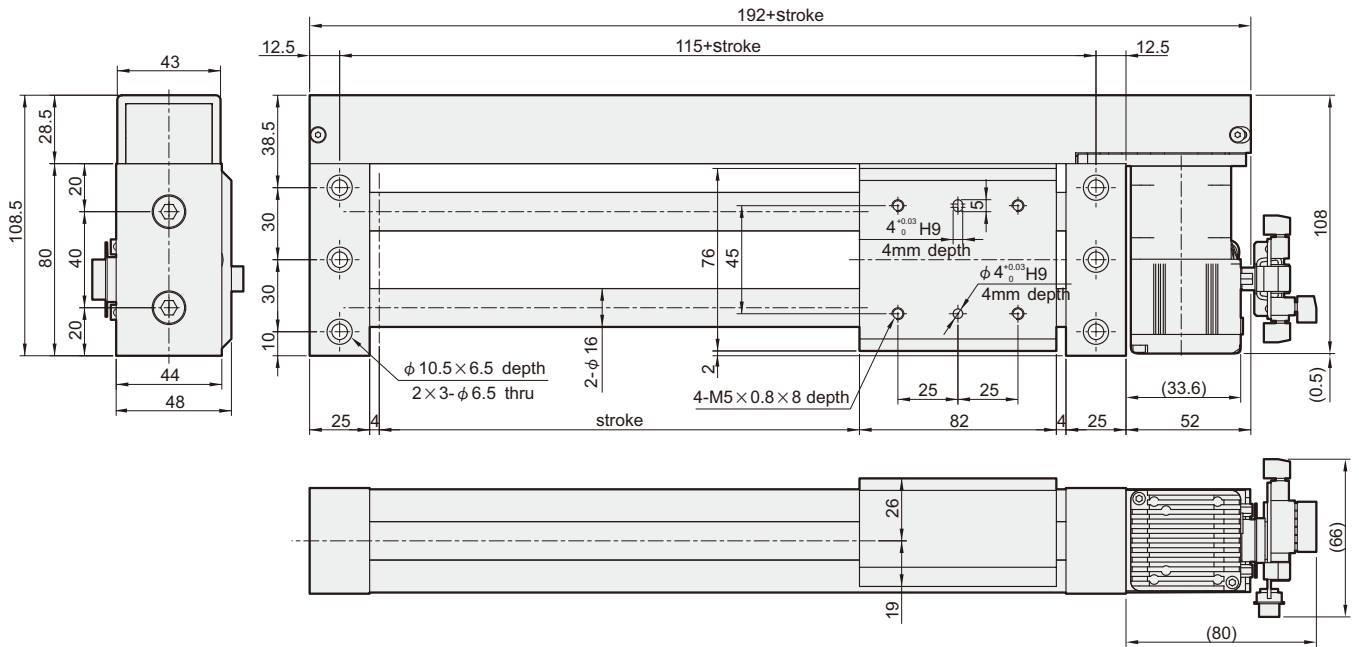

### Expansion I/O card

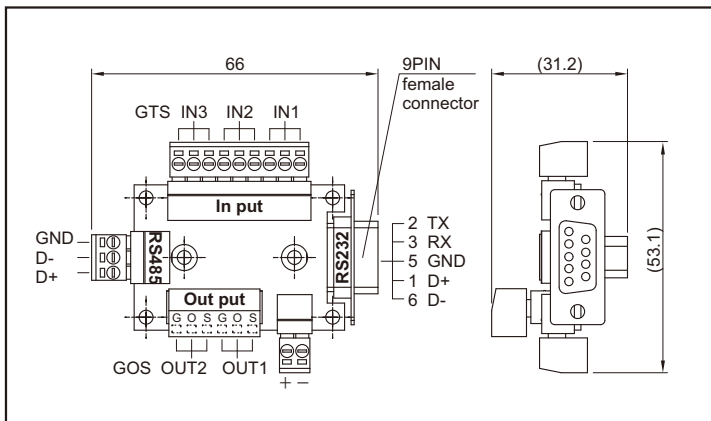

※ When in control mode, all inputs/outputs are not defined and should be defined by program. (I/O card is optional)

### Order example

EAT - 1

Expansion I/O card

### Outputs/inputs circuit diagram

