

METS-12 series

SLIDER ELECTRIC CYLINDER - BALL SCREW DRIVE (WITHOUT MOTOR)



mindman



Specification

Model	METS-12				
Repeatability (mm)	±0.01				
Belt lead (mm)	5	10	16	20	
Max. speed (mm/s)	250	500	800	1000	
Servo motor	100W				
Max. payload(kg)	Horizontal	50	30	22	18
	Vertical	12	8	5	3
Rated thrust (N)	341	170	106	85	
Stroke (mm)	100~1050 / 50 pitch				
Ball screw ϕ (mm)	C7 ϕ 16				
High rigidity linear guide (mm)	W12 \times H7.5				
Coupling (mm)	10 \times 8				
Home sensor	Outside	EE-SX672 (NPN)			
	Built in	EE-SX674 (NPN)			

Sensor layout

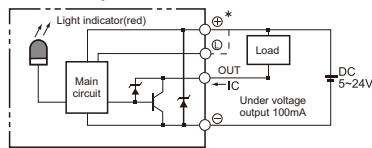

Order example

METS-12 — **L16** — **100** — **M** — **M10B** — **C4** — **0001**

Model Spec. Stroke Special order no.

100~1050 mm
50 mm pitch

Ball screw brand	Ball screw lead	Motor position	Motor brand, power output, brakes	Home sensor	Limit sensor
L T-Standard MIT	05 5 mm 10 10 mm 16 16 mm 20 20 mm	M Built-in BC Exposed BM On lower side BR On right side BL On left side	100W SERVO motor M Mitsubishi P Panasonic Y Yaskawa T Delta	In side A Motor side B Opposite motor side Out side C Motor side D Opposite motor side No sensor E None	In side 1 1 Pc 2 2 Pcs Out side 3 1 Pc 4 2 Pcs No sensor 5 None

※ Need not show **B** with no brake.

Allowable overhang N.m

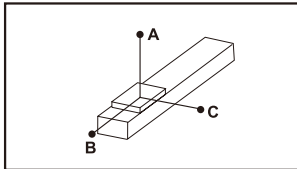

Unit: mm

Horizontal installation		A	B	C
Lead 5	30kg	1200	158	311
	50kg	1100	124	124
-	-	-	-	-
Lead 10	15kg	1000	190	250
	25kg	900	190	170
	30kg	850	124	122
Lead 16	5kg	2150	1365	982
	10kg	1190	462	427
	22kg	1270	242	291
Lead 20	5kg	1936	1229	882
	10kg	1039	418	387
	15kg	1073	220	264

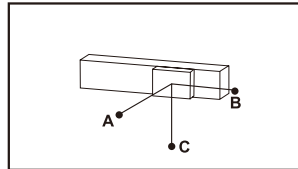

Unit: mm

Wall installation		A	B	C
Lead 5	10kg	126	60	800
	20kg	70	30	600
	30kg	50	15	476
Lead 10	10kg	246	180	700
	20kg	150	80	515
	30kg	72	32	422
Lead 16	5kg	1068	976	1579
	10kg	405	278	776
	22kg	220	107	680
Lead 20	5kg	958	875	1420
	10kg	361	248	696
	15kg	107	95	610

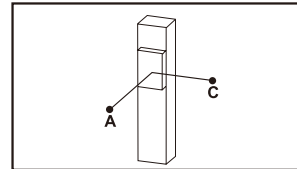

Unit: mm

Vertical installation		A	C
Lead 5	5kg	412	398
	10kg	394	356
	12kg	357	355
Lead 10	5kg	711	578
	6kg	534	414
	8kg	411	376
Lead 16	1kg	1210	1210
	2kg	1174	1174
	5kg	650	650
Lead 20	-	-	-
	-	-	-
	3kg	1030	802

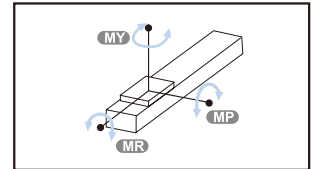

Unit: N.m

Static loading moment	
MY	150
MP	150
MR	130

Standard servo motors

Brand	Mark	Brake	Watr	AC-Voltage	Motor model	Compatible driver model
Mitsubishi	M	No brake(Horizontal type)	100	220	HP-KP13	MR-J3-10A
		With brake(Vertical type)	100	220	HP-KP13B	MR-J3-10A
Panasonic	P	No brake(Horizontal type)	100	220	MSMD012P1S	MADDT1205
		With brake(Vertical type)	100	220	MSMD012P1T	MADDT1205
Delta	T	No brake(Horizontal type)	100	220	ECMA-C20401ES	ASD-B20121-B
		With brake(Vertical type)	100	220	ECMA-C20401FS	ASD-B20121-B

METS-12 Servo motor 100W/Dimensions



SLIDER ELECTRIC CYLINDER - BALL SCREW DRIVE (WITHOUT MOTOR)

mindman

BC
Motor exposed

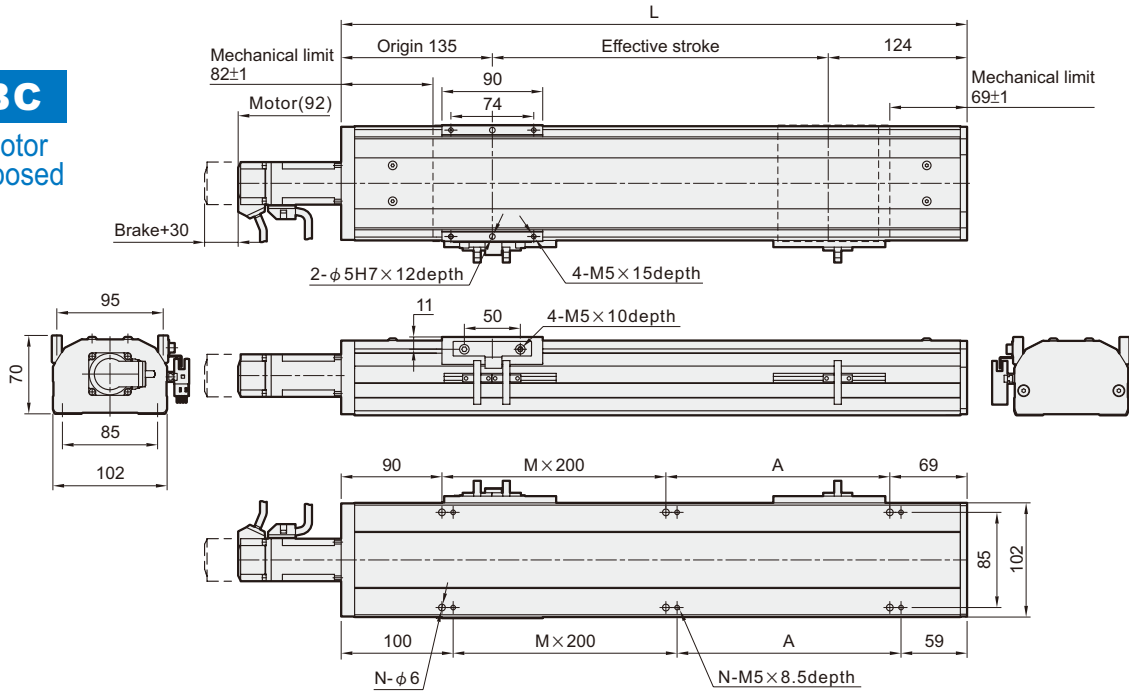

Unit: mm

Stroke	100	150	200	250	300	350	400	450	500	550	600	650	700	750	800	850	900	950	1000	1050
L	359	409	459	509	559	609	659	709	759	809	859	909	959	1009	1059	1109	1159	1209	1259	1309
A	200	50	100	150	200	50	100	150	200	50	100	150	200	50	100	150	200	50	100	150
M	0	1	1	1	1	2	2	2	2	3	3	3	3	4	4	4	4	5	5	5
N	4	6	6	6	6	8	8	8	8	10	10	10	10	12	12	12	12	14	14	14
KG	5.07	5.46	5.84	6.23	6.62	7.01	7.04	7.78	8.17	8.56	8.95	9.34	9.72	10.11	10.5	10.89	11.28	11.66	12.05	12.44

M
Motor built-in

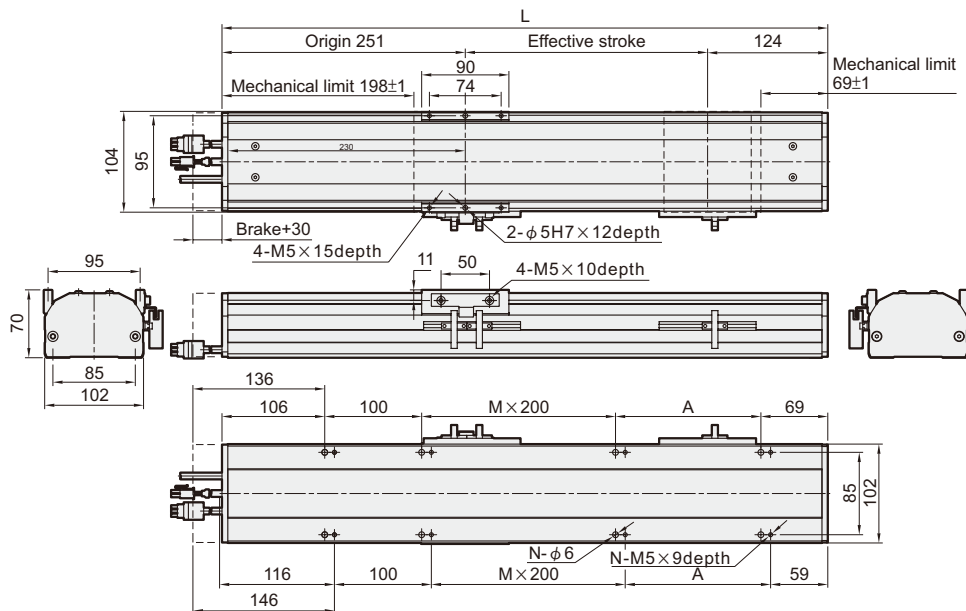

Unit: mm

Stroke	100	150	200	250	300	350	400	450	500	550	600	650	700	750	800	850	900	950	1000	1050
L	475	525	575	625	675	725	775	825	875	925	975	1025	1075	1125	1175	1225	1275	1325	1375	1425
A	200	50	100	150	200	50	100	150	200	50	100	150	200	50	100	150	200	50	100	150
M	0	1	1	1	1	2	2	2	2	3	3	3	3	4	4	4	4	5	5	5
N	6	8	8	8	8	10	10	10	10	12	12	12	12	14	14	14	14	16	16	16
KG	5.54	5.93	6.32	6.71	7.1	7.49	7.88	8.27	8.66	9.05	9.44	9.83	10.22	10.61	11	11.39	11.78	12.17	12.56	12.95

METS-12 Servo motor 100W/Dimensions



SLIDER ELECTRIC CYLINDER - BALL SCREW DRIVE (WITHOUT MOTOR)

mindman

BL
Motor on left side

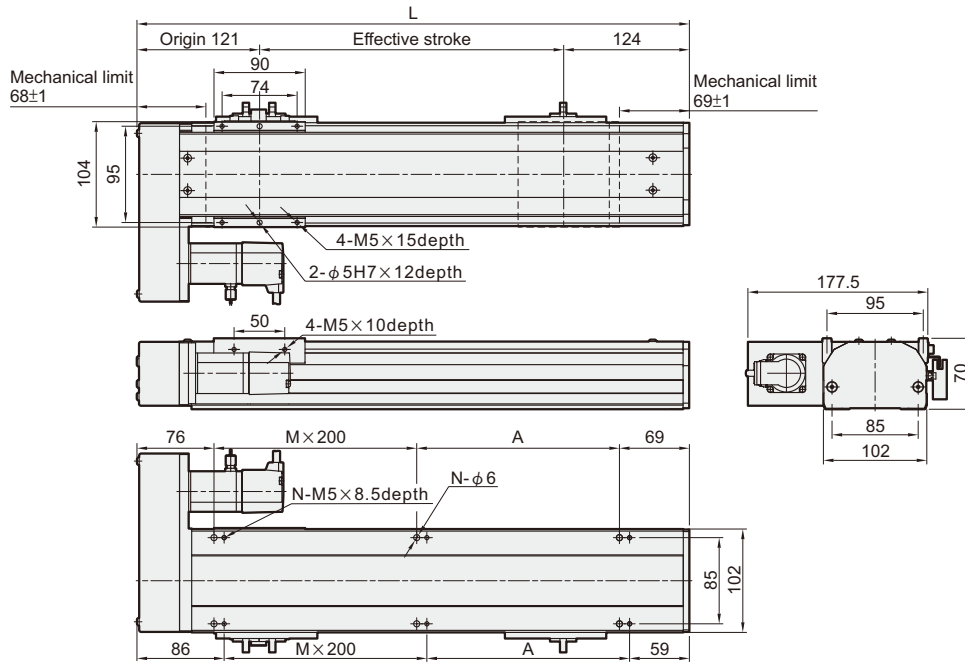

Unit: mm

Stroke	100	150	200	250	300	350	400	450	500	550	600	650	700	750	800	850	900	950	1000	1050
L	345	395	445	495	545	595	645	695	745	795	845	895	945	995	1045	1095	1145	1195	1245	1295
A	200	50	100	150	200	50	100	150	200	50	100	150	200	50	100	150	200	50	100	150
M	0	1	1	1	1	2	2	2	2	3	3	3	3	4	4	4	4	5	5	5
N	4	6	6	6	6	8	8	8	8	10	10	10	10	12	12	12	12	14	14	14
KG	5.45	5.84	6.23	6.61	7	7.39	7.77	8.16	8.55	8.94	9.32	9.71	10.1	10.48	10.87	11.26	11.64	12.03	12.42	12.81

BR
Motor on right side

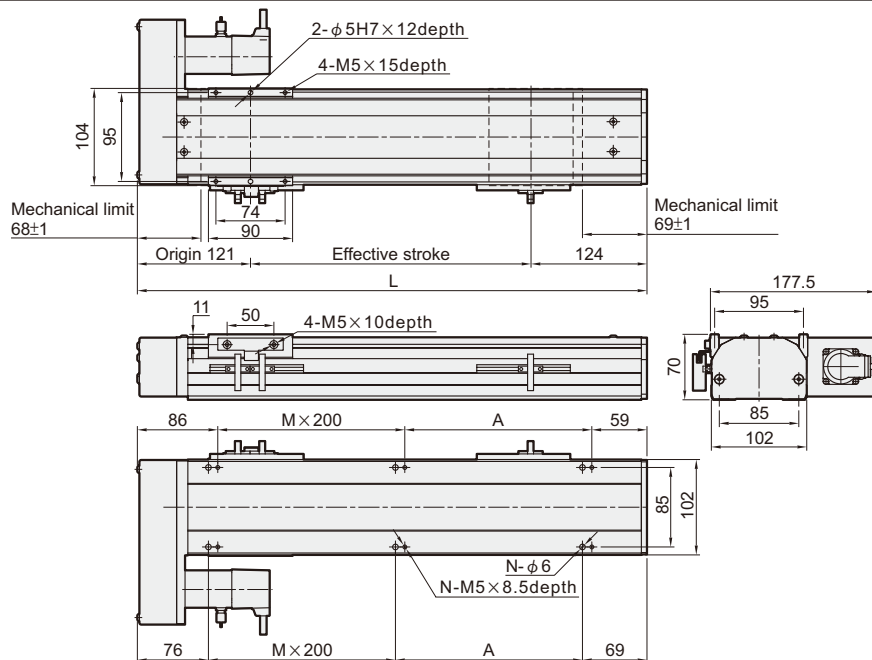

Unit: mm

Stroke	100	150	200	250	300	350	400	450	500	550	600	650	700	750	800	850	900	950	1000	1050
L	345	395	445	495	545	595	645	695	745	795	845	895	945	995	1045	1095	1145	1195	1245	1295
A	200	50	100	150	200	50	100	150	200	50	100	150	200	50	100	150	200	50	100	150
M	0	1	1	1	1	2	2	2	2	3	3	3	3	4	4	4	4	5	5	5
N	4	6	6	6	6	8	8	8	8	10	10	10	10	12	12	12	12	14	14	14
KG	5.45	5.84	6.23	6.61	7	7.39	7.77	8.16	8.55	8.94	9.32	9.71	10.1	10.48	10.87	11.26	11.64	12.03	12.42	12.81

METS-12 Servo motor 100W/Dimensions



SLIDER ELECTRIC CYLINDER - BALL SCREW DRIVE (WITHOUT MOTOR)

mindman

BM
Motor on lower side

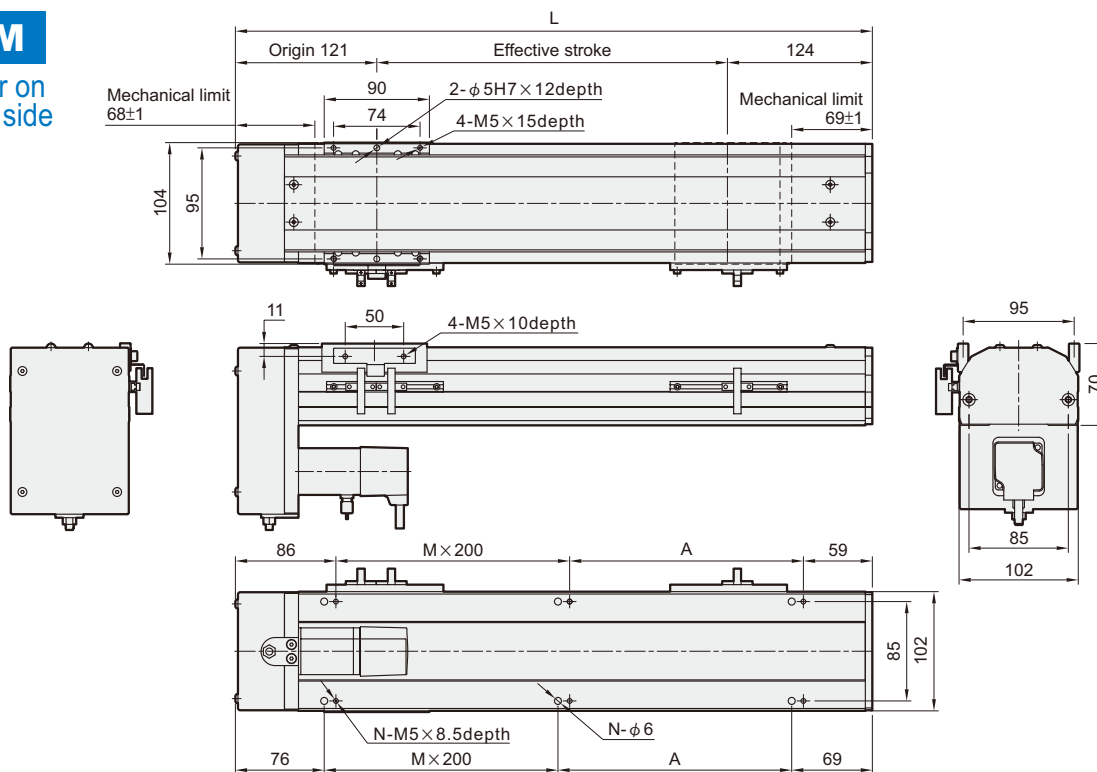

Unit: mm

Stroke	100	150	200	250	300	350	400	450	500	550	600	650	700	750	800	850	900	950	1000	1050
L	345	395	445	495	545	595	645	695	745	795	845	895	945	995	1045	1095	1145	1195	1245	1295
A	200	50	100	150	200	50	100	150	200	50	100	150	200	50	100	150	200	50	100	150
M	0	1	1	1	1	2	2	2	2	3	3	3	3	4	4	4	4	5	5	5
N	4	6	6	6	6	8	8	8	8	10	10	10	10	12	12	12	12	14	14	14
KG	5.45	5.84	6.23	6.61	7	7.39	7.77	8.16	8.55	8.94	9.32	9.71	10.1	10.48	10.87	11.26	11.64	12.03	12.42	12.81