

METS-14 series

SLIDER ELECTRIC CYLINDER - BALL SCREW DRIVE (WITHOUT MOTOR)



mindman



Sensor layout

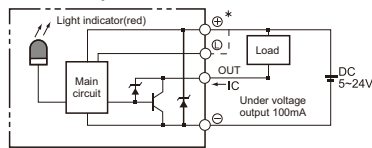

Specification

Model	METS-14			
Repeatability (mm)	±0.01			
Belt lead (mm)	5	10	16	20
Max. speed(mm/s)	250	500	800	1000
Stroke (mm)	100~1050 / 50 pitch			
Ball screw φ (mm)	C7 φ 16			
High rigidity linear guide (mm)	W15×H12.5			
Coupling (mm)	10×14			
Home sensor	Outside	EE-SX672 (NPN)		
	Built in	EE-SX674 (NPN)		

Servo motor	200W				
Max. payload(kg)	Horizontal	95	75	44	35
	Vertical	27	18	7	6
Rated thrust (N)	683	341	213	174	

Servo motor	400W				
Max. payload(kg)	Horizontal	110	88	48	40
	Vertical	33	22	10	8
Rated thrust (N)	1388	694	433	347	

Order example

METS-14 — **L05** — **100** — **M** — **M20B** — **C4** — **0001**

Model Spec. Stroke 100~1050 mm 50 mm pitch Special order no.

Ball screw brand	Ball screw lead	Motor position	Motor brand, power output, brakes	Home sensor	Limit sensor
L T-Standard MIT	05 5 mm 10 10 mm 16 16 mm 20 20 mm	M Built-in BC Exposed BM On lower side BR On right side BL On left side	M Mitsubishi P Panasonic Y Yaskawa T Delta 20:200W 40:400W B	In side A Motor side B Opposite motor side Out side C Motor side D Opposite motor side No sensor E None	In side 1 1 Pc 2 2 Pcs Out side 3 1 Pc 4 2 Pcs No sensor 5 None

※ Need not show B with no brake.

METS-14 Performance charts 200W/400W



SLIDER ELECTRIC CYLINDER - BALL SCREW DRIVE (WITHOUT MOTOR)

mindman

Allowable overhang N.m

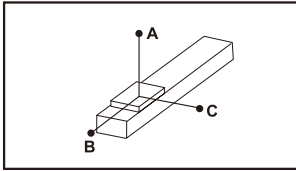

Unit: mm

Horizontal installation		A	B	C
Lead 5	60kg	2448	316	322
	80kg	2197	247	257
	95kg	2005	207	219
Lead 10	30kg	1958	370	490
	50kg	1660	370	333
	75kg	1725	247	243
Lead 16	10kg	2265	1674	961
	20kg	1402	855	537
	44kg	1047	445	324
Lead 20	10kg	2263	1672	958
	20kg	1400	852	535
	35kg	1052	448	328

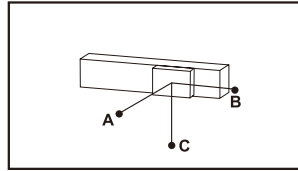

Unit: mm

Wall installation		A	B	C
Lead 5	60kg	204	112	1394
	80kg	130	57	1115
	95kg	85	24	895
Lead 10	30kg	414	333	1277
	50kg	235	157	929
	75kg	129	57	751
Lead 16	10kg	461	372	1410
	20kg	264	178	1027
	44kg	148	69	832
Lead 20	10kg	997	1217	1709
	20kg	513	555	985
	35kg	268	231	640

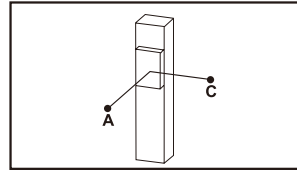

Unit: mm

Vertical installation		A	C
Lead 5	20kg	762	614
	25kg	607	489
	27kg	498	483
Lead 10	10kg	1365	1101
	15kg	901	727
	18kg	674	543

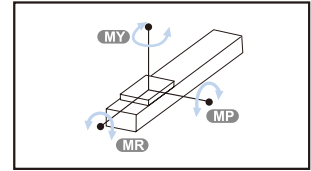

Unit: N.m

Static loading moment	
MY	551
MP	552
MR	485

As stated METS-14/400W, section 3 of the table stating lead 5, lead 10, lead 16 and lead 20. The acceptable moment load are lead 5/110kg, lead 10/88kg, lead 16/48kg and lead 20/40kg and the length of three axis is the same.

200W			
Lead 16	2kg	2420	2031
	4kg	1690	1360
	7kg	1300	1050
Lead 20	6kg	1695	1361
	-	-	-
	-	-	-

400W			
Lead 16	2kg	1067	1217
	4kg	997	805
	10kg	747	603
Lead 20	4kg	2402	2018
	6kg	1701	1366
	8kg	1305	1055

Standard servo motors

Brand	Mark	Brake	Watt	AC-Voltage	Motor model	Compatible driver model
Mitsubishi	M	No brake(Horizontal type)	200	220	HF-KP23	MR-J3-20A
			400	220	HF-KP43	MR-J3-40A
		With brake(Vertical type)	200	220	HF-KP23B	MR-J3-20A
			400	220	HF-KP43B	MR-J3-40A
Panasonic	P	No brake(Horizontal type)	200	220	MHMD022P1S	MADDT1207
			400	220	MHMD042P1S	MADDT2210
		With brake(Vertical type)	200	220	MHMD022P1T	MADDT1207
			400	220	MHMD042P1T	MADDT2210
Delta	T	No brake(Horizontal type)	200	220	ECMA-C20602ES	ASD-B20221-B
			400	220	ECMA-C20604ES	ASD-B20421-B
		With brake(Vertical type)	200	220	ECMA-C20602FS	ASD-B20221-B
			400	220	ECMA-C20604FS	ASD-B20421-B

METS-14 Servo motor 200W/ 400W/Dimensions

SLIDER ELECTRIC CYLINDER - BALL SCREW DRIVE (WITHOUT MOTOR)



BC
Motor exposed



Unit: mm

Stroke	100	150	200	250	300	350	400	450	500	550	600	650	700	750	800	850	900	950	1000	1050
L	350	400	450	500	550	600	650	700	750	800	850	900	950	1000	1050	1100	1150	1200	1250	1300
A	50	100	150	200	50	100	150	200	50	100	150	200	50	100	150	200	50	100	150	200
M	1	1	1	1	2	2	2	2	3	3	3	3	4	4	4	4	5	5	5	5
N	6	6	6	6	8	8	8	8	10	10	10	10	12	12	12	12	14	14	14	14
KG	9.3	9.85	10.4	10.95	11.5	12.05	12.6	13.15	13.7	14.25	14.8	15.35	15.9	16.45	17	17.55	18.1	18.65	19.2	19.75

M
Motor built-in

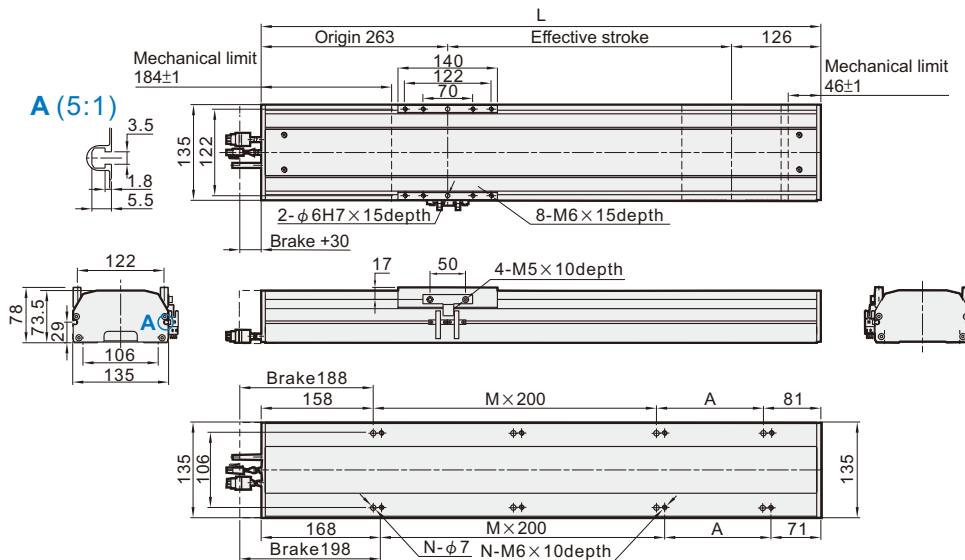

Unit: mm

Stroke	100	150	200	250	300	350	400	450	500	550	600	650	700	750	800	850	900	950	1000	1050
L	489	539	589	639	689	739	789	839	889	939	989	1039	1089	1139	1189	1239	1289	1339	1389	1439
A	50	100	150	200	50	100	150	200	50	100	150	200	50	100	150	200	50	100	150	200
M	1	1	1	1	2	2	2	2	3	3	3	3	4	4	4	4	5	5	5	5
N	6	6	6	6	8	8	8	8	10	10	10	10	12	12	12	12	14	14	14	14
KG	10.06	10.62	11.18	11.74	12.3	12.86	13.42	13.98	14.54	15.1	15.66	16.22	16.78	17.34	17.9	18.46	19.02	19.58	20.14	20.7

METS-14 Servo motor 200W/ 400W/Dimensions



SLIDER ELECTRIC CYLINDER - BALL SCREW DRIVE (WITHOUT MOTOR)

mindman

BL
Motor on left side

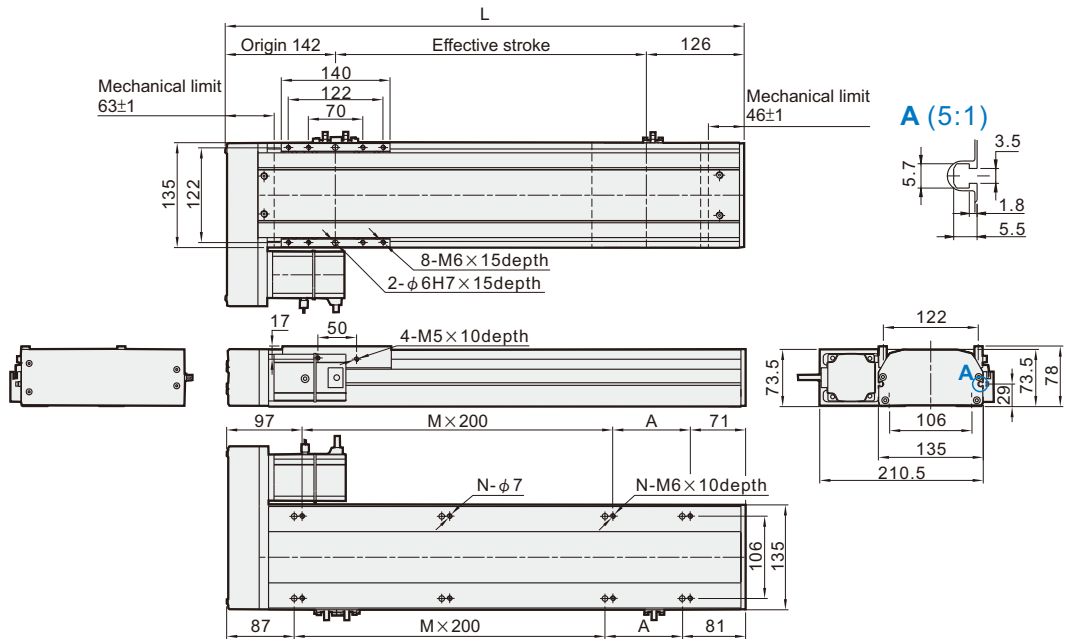

Unit: mm

Stroke	100	150	200	250	300	350	400	450	500	550	600	650	700	750	800	850	900	950	1000	1050
L	368	418	468	518	568	618	668	718	768	818	868	918	968	1018	1068	1118	1168	1218	1268	1318
A	200	50	100	150	200	50	100	150	200	50	100	150	200	50	100	150	200	50	100	150
M	0	1	1	1	1	2	2	2	2	3	3	3	3	4	4	4	4	5	5	5
N	4	6	6	6	6	8	8	8	8	10	10	10	10	12	12	12	12	14	14	14
KG	9.94	10.48	11.02	11.56	12.1	12.64	13.18	13.72	14.26	14.8	15.34	15.88	16.42	16.96	17.5	18.04	18.58	19.12	19.66	20.2

BR
Motor on right side

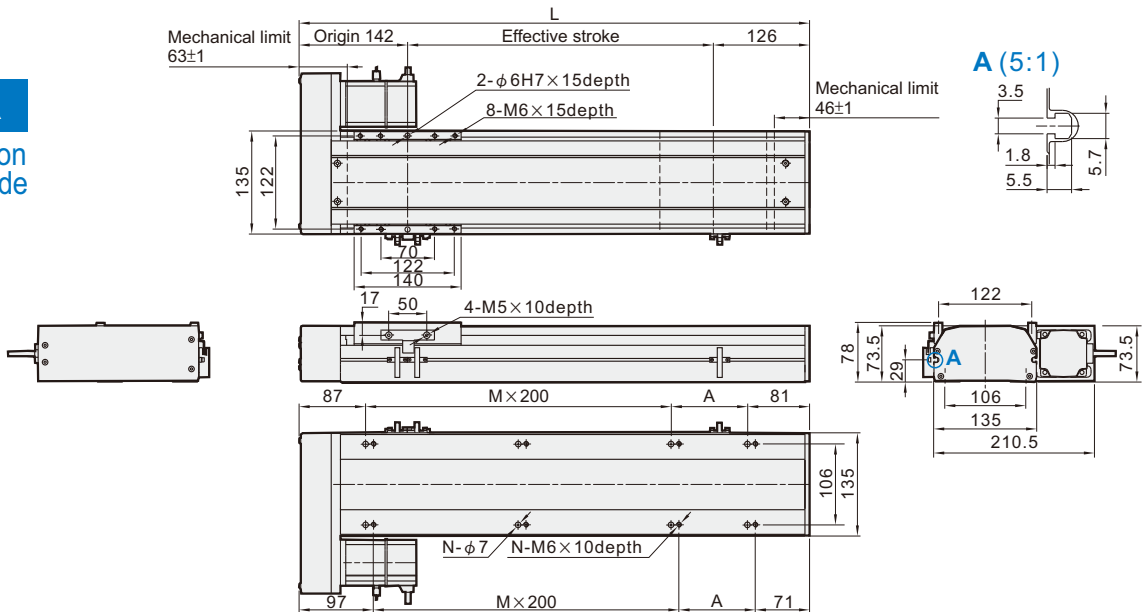

Unit: mm

Stroke	100	150	200	250	300	350	400	450	500	550	600	650	700	750	800	850	900	950	1000	1050
L	368	418	468	518	568	618	668	718	768	818	868	918	968	1018	1068	1118	1168	1218	1268	1318
A	200	50	100	150	200	50	100	150	200	50	100	150	200	50	100	150	200	50	100	150
M	0	1	1	1	1	2	2	2	2	3	3	3	3	4	4	4	4	5	5	5
N	4	6	6	6	6	8	8	8	8	10	10	10	10	12	12	12	12	14	14	14
KG	9.94	10.48	11.02	11.56	12.1	12.64	13.18	13.72	14.26	14.8	15.34	15.88	16.42	16.96	17.5	18.04	18.58	19.12	19.66	20.2

METS-14 Servo motor 200W/ 400W/Dimensions

SLIDER ELECTRIC CYLINDER - BALL SCREW DRIVE (WITHOUT MOTOR)



BM

Motor on lower side

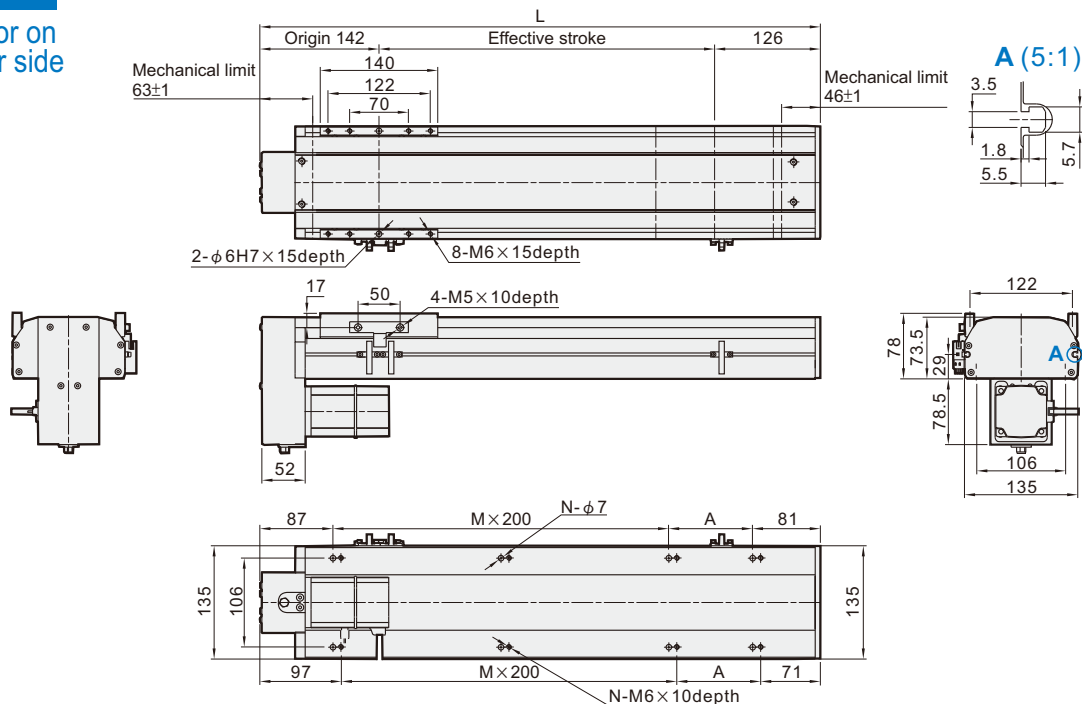

Unit: mm

Stroke	100	150	200	250	300	350	400	450	500	550	600	650	700	750	800	850	900	950	1000	1050
L	368	418	468	518	568	618	668	718	768	818	868	918	968	1018	1068	1118	1168	1218	1268	1318
A	200	50	100	150	200	50	100	150	200	50	100	150	200	50	100	150	200	50	100	150
M	0	1	1	1	1	2	2	2	2	3	3	3	3	4	4	4	4	5	5	5
N	4	6	6	6	6	8	8	8	8	10	10	10	10	12	12	12	12	14	14	14
KG	9.94	10.48	11.02	11.56	12.1	12.64	13.18	13.72	14.26	14.8	15.34	15.88	16.42	16.96	17.5	18.04	18.58	19.12	19.66	20.2