

MVSI-510 series

ISO-3 SOLENOID VALVE

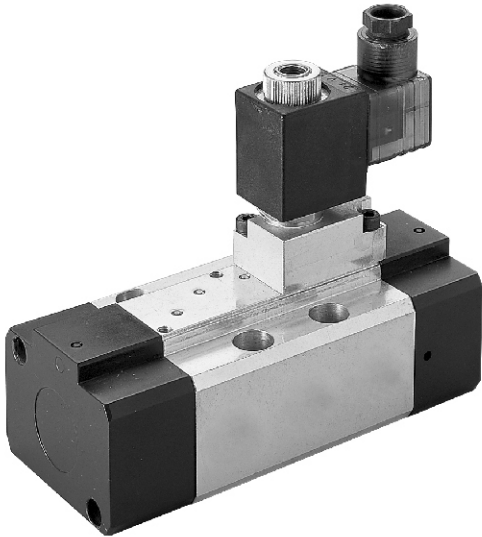

Specification:

Model	MVSI-510-4E1	MVSI-510-4E2
No. of port	5	
No. of position	2	
Medium	Air	
Operating pressure range	2~7 kgf/cm ²	
Proof pressure	10 kgf/cm ²	
Effective orifice	65 mm ²	
Response time	60 ms	
Ambient temperature	-5~+50°C (No freezing)	
Voltage	AC110V, 220V (50/60)Hz, DC24V	
Power consumption	AC=13/11VA, DC=10W	
Available voltage range	±10%	
Insulation class	H class	
Weight	1493 g	1778 g

Order example of valve:

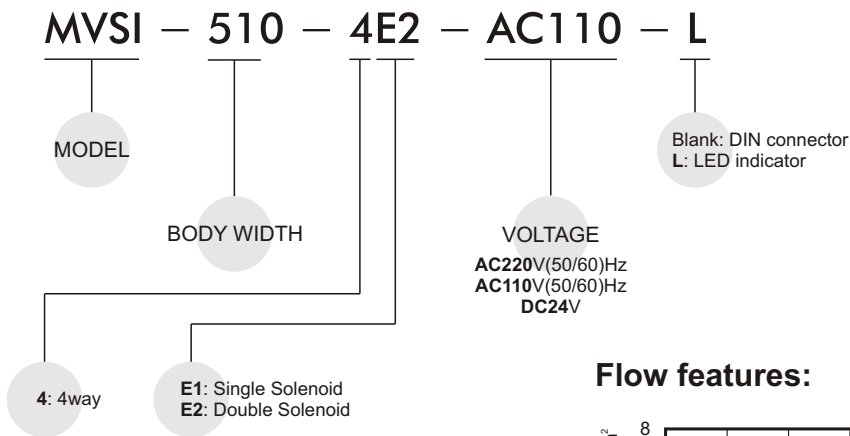

Flow features:

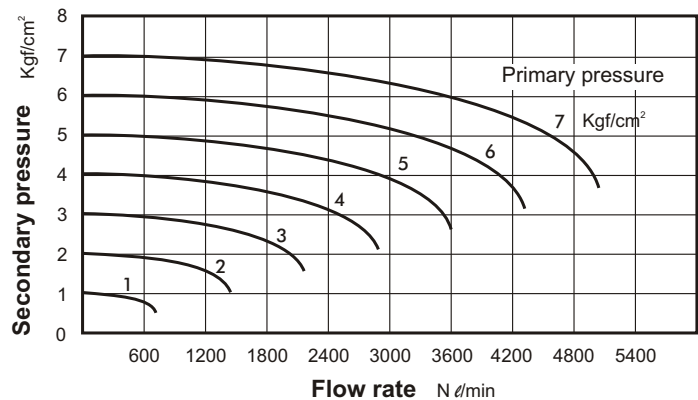

MVSI-510

ISO-3 SOLENOID VALVE



Mindman

Dimensions:

MVSI-510-4E1

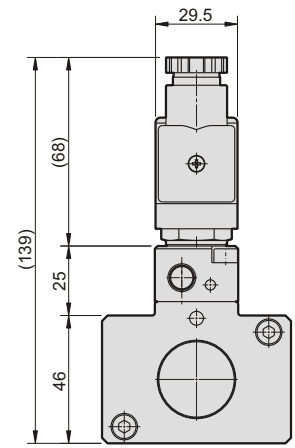
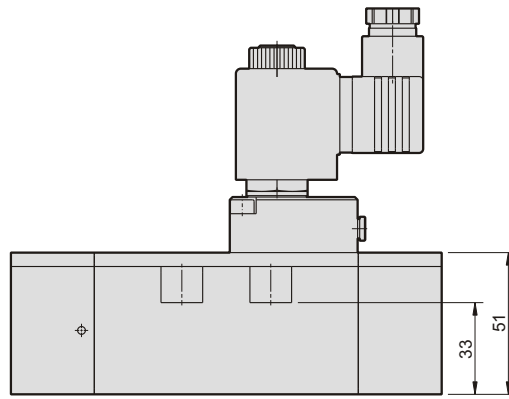
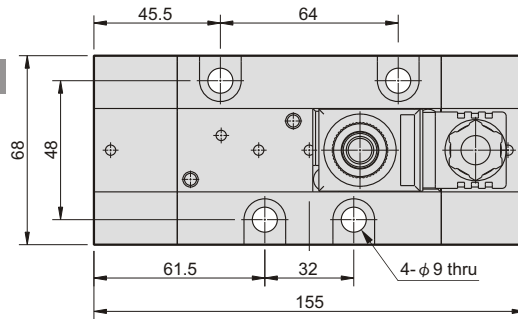

MVSI-510-4E2

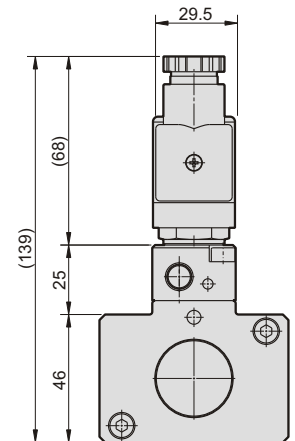
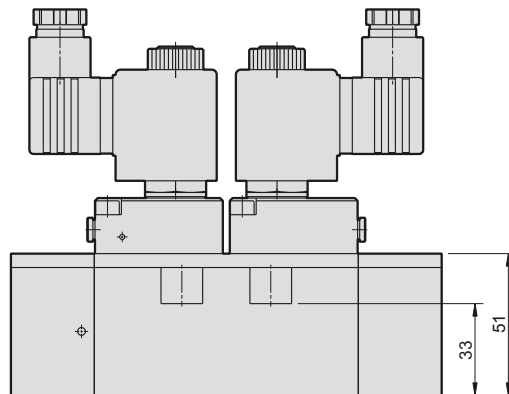
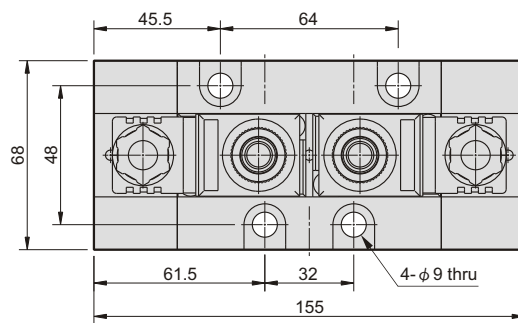

Accessories

