

# MZL212 series

## MULTISTAGE VACUUM PUMP



### Specification

Model	MZL212
Nozzle dia.	1.2 mm × 2
Max. suction flow	200 ℓ/min
Air consumption	126 ℓ/min
Max. vacuum pressure	-84 kPa
Max. operating pressure	0.7 MPa
Supply pressure range	0.2~0.5 MPa
Standard supply pressure	0.4 MPa
Operating temperature range	+5~+50°C
Weight	700 g

### Order example

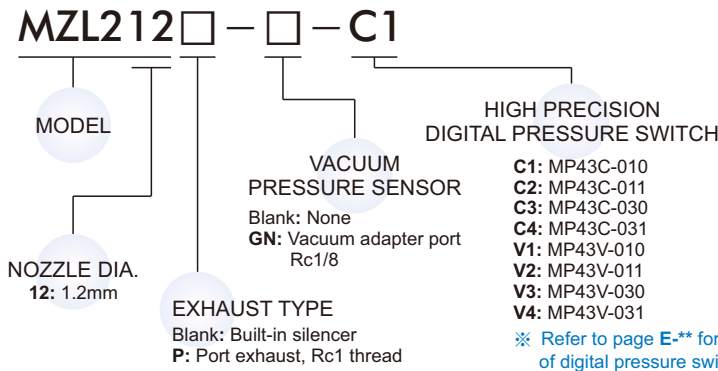

### 3 stage diffuser construction

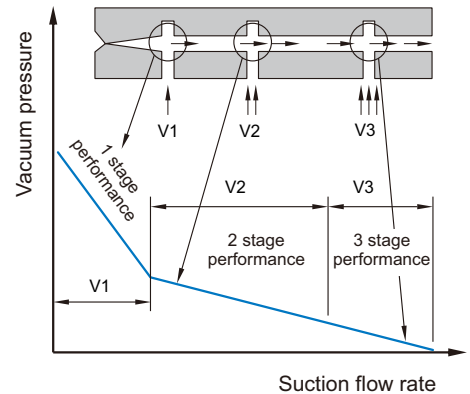

### Vacuum flow(ℓ/min) at different vacuum levels(-kPa)

Supply pressure	Air consumption	Vacuum flow(ℓ/min) at different vacuum levels(-kPa)									Max. vacuum level
		0	10	20	30	40	50	60	70	80	
0.4 MPa	125 ℓ/min	0	10	20	30	40	50	60	70	80	-84 kPa
		200	150	52	40	30	25	15	8	3	

### Evacuation time(s/ℓ) to reach different vacuum levels(-kPa)

Supply pressure	Air consumption	Evacuation time(s/ℓ) to reach different vacuum levels(-kPa)									Max. vacuum level
		10	20	30	40	50	60	70	80		
0.4 MPa	125 ℓ/min	0.011	0.076	0.246	0.415	0.646	0.98	1.52	2.46	-84 kPa	

### Vacuum characteristics

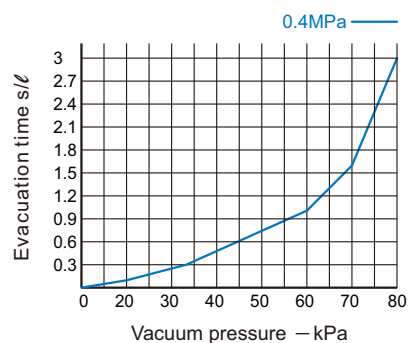
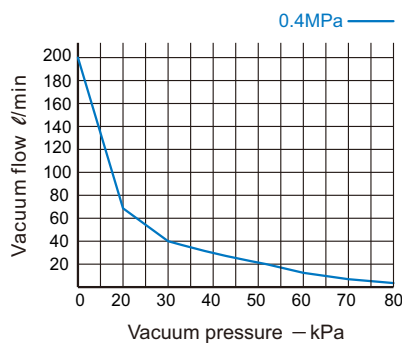

# MZL212 Dimensions

## MULTISTAGE VACUUM PUMP



### MZL212

Standrd

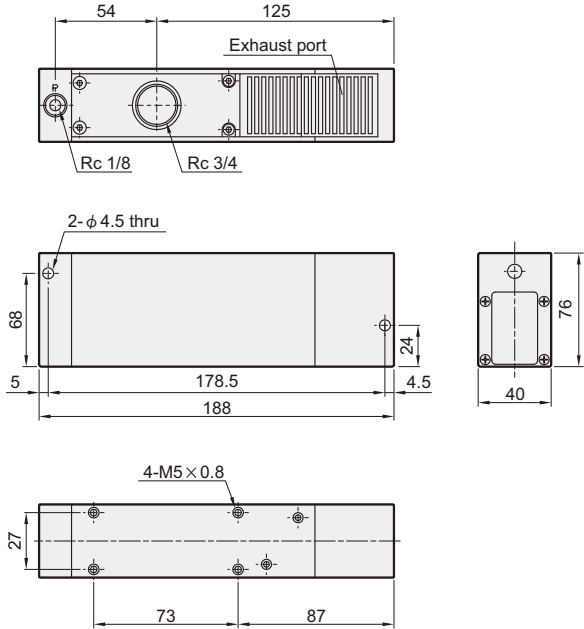

### MZL212P

Port exhaust

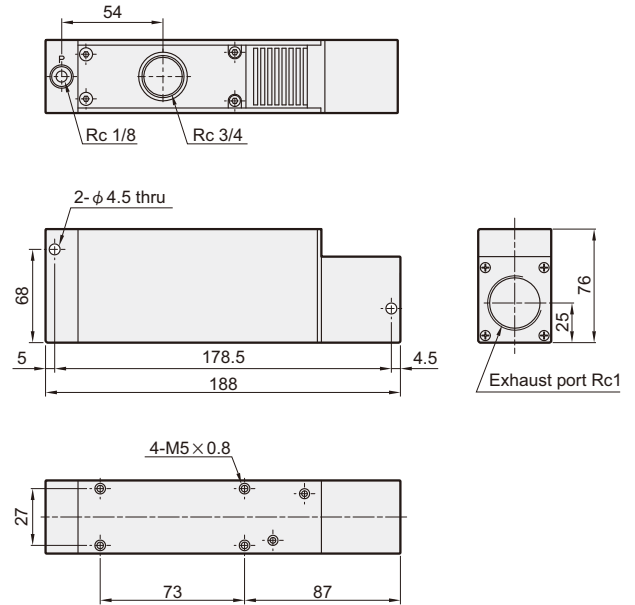

### MZL212-GN

With vacuum adapter

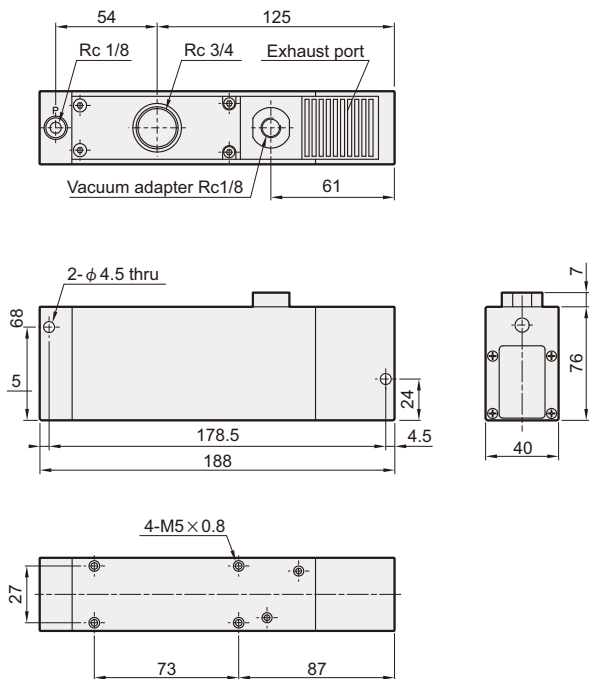

### MZL212-GN-C\*

With high precision digital pressure switch

